

WATERBOSS[®]

MODELS PRO 180/PROPLUS 380

OWNER'S MANUAL



Next >

IF YOU NEED HELP OR HAVE A QUESTION, WE'VE GOT YOU COVERED.
GIVE US A CALL AT 1-800-437-8993. PLEASE DO NOT RETURN TO THE STORE.



Water Softening by WaterBoss®

Congratulations on choosing a superior WaterBoss® water treatment appliance. Keep this owner's manual to reference installation, troubleshooting and replacement information. If you have issues with the operation of your appliance, see the troubleshooting guide in the back of this manual or contact the HelpLine at 1-800-437-8993 from 8AM to 5PM. ET. Help is also available on the WaterBoss® website: www.waterboss.com.

WATER SOFTENERS

TABLE OF CONTENTS

Box Contents	3
Maximum Efficiency	4
Checklist Before Installation.....	5-6
Precautions	7
Installation Guide.....	8-13
Bypass Valve.....	14
Program Controller	15-17
Advanced Customer Settings	18-19
System Overview.....	20-22
WaterBoss® Water Condition Specifications.....	23
Efficiency Statements	24-25
Troubleshooting.....	26-28
Warranty	29-30

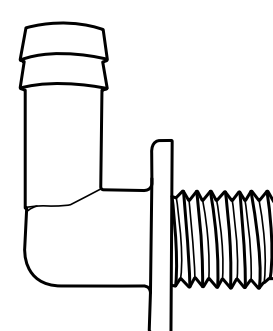
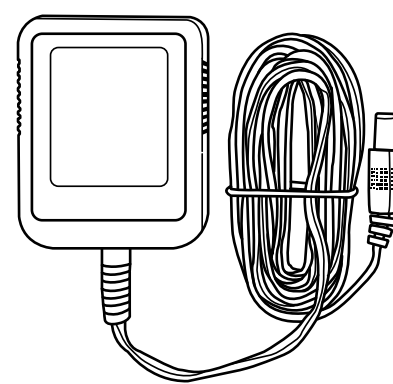
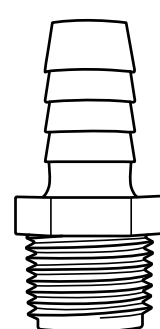
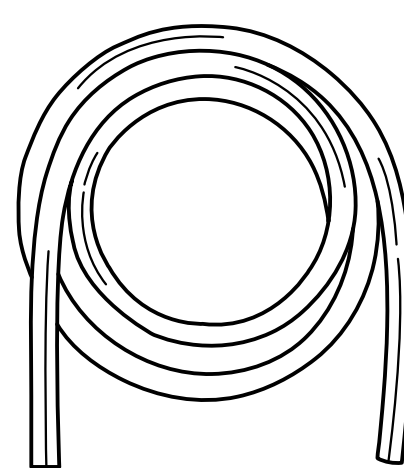
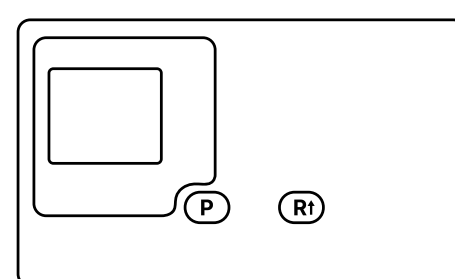
WATER SOFTENER**OVERFLOW ELBOW****12V TRANSFORMER****V-185 NOZZLE****DRAIN LINE****CONTROLLER**

Please read entire manual to ensure all parts listed are present before installation. If any part is missing or damaged let us know by calling 1-800-437-8993. Do not attempt to install the softener.

Tools & parts recommended for installation:

- Crescent wrench
- Fittings 3/4" to 1"
- Pliers
- Hose clamp
- Screwdriver

Note: We recommend using a professional if pipe cutting or drilling is required. Basic plumbing knowledge is recommended prior to installation.

To achieve the maximum benefit and performance from this appliance, familiarize yourself with this manual and the appliance.

1. The salt level should always be at least 1/3 full. Refill the salt when the level drops below the water level in the brine cabinet. A resin cleaner can be used on a monthly basis. A clean pellet, solar, or cube type salt is recommended. Do not use rock salt.

Caution: Do not mix different types of salt.

2. You may switch to a salt substitute (such as potassium chloride) in place of water conditioner salt at any time. If potassium chloride is used in place of salt, increase your hardness setting by 12% (multiply by 1.12). See Setting the Controller.

Caution: Do not use potassium chloride if your water contains iron and/or manganese.

3. Should your electricity be off for any reason check your controller for the correct time and reset as necessary (See Advanced Customer Settings)
4. Program the appliance to regenerate at a time when the water is not being used. If there is more than one appliance, allow two hours between each regeneration.
5. Protect the appliance, including the drain line, from freezing.
6. Adhere to all operational, maintenance, and placement requirements.
7. If your appliance runs out of salt:
 - A. Open the salt lid and add salt.
 - B. Wait two hours, then press and hold the R▲ button for 5 seconds.
 - C. Regeneration is complete after approximately 12 to 45 minutes, and the appliance is returned to Normal Operation.
8. If dirt, sand, or large particles are present in the water supply, the appropriate WaterBoss® filter can eliminate this problem.
9. The appliance may be disinfected with 5.25% sodium hypochlorite, which is the active ingredient in household chlorine bleach. To disinfect the appliance, add 4.0 fluid ounces (120 mL) of chlorine bleach solution to the brine well of the brine cabinet. The brine cabinet should have water in it. Start a manual regeneration.
10. The bypass valve (located on the main control valve) enables you to bypass the appliance if any work is being performed on the appliance, well pump, or plumbing. See Bypass Valve. Use Bypass mode also for watering plants or lawns with untreated water.
11. Before putting the appliance back in service after work has been performed, turn on the nearest cold water tap until water runs clear.
12. Inspect and clean the brine cabinet and air check/draw tube assembly annually or when sediment is present in the brine cabinet.
13. Potassium permanganate will need to be added periodically to any iron filter.
14. This product is certified for barium and radium 226/228 reduction according to NSF/ANSI Standard 44. Any Bypass system must be completely in the Service position to ensure maximum barium and radium 226/228 reduction.

Refer to this checklist before installation.

Water Quality — If the water supply contains sand, sulfur, bacteria, iron bacteria, tannins, algae, oil, acid, or other unusual substances, consider pre-treating the water to remove these contaminants before the water supply enters the appliance, unless the appliance is represented as being capable of treating these contaminants in its specifications.

The appropriate WaterBoss® Water Filter can address these water concerns.

- Model 900-IF (Iron Filter) — Reduces iron, manganese, hydrogen sulfide, and iron bacteria.
- Model 900-NF (Acid Neutralizing filter) — Adjusts low pH water to a non-corrosive state.

Iron — A common problem found in many water supplies is iron. It is important to know what type of and how much iron is in the water supply.

IRON TYPE	DESCRIPTION
Ferrous Iron* (sometimes called clear water or dissolved iron)	Only type of iron that can be treated with a water softener
Ferric Iron	Insoluble and the particles can eventually foul a resin bed. It should be filtered out before the water reaches the softener
Organic Iron or Bacterial Iron	Attached to other organic compounds in the water. Additional treatment is needed to remove this type of iron
Colloidal Iron	Not dissolved, yet stays in suspension. A softener cannot remove this type of iron

*If the water supply contains ferrous iron, a commercially available resin bed cleaner should be used every six months. Follow the instructions on the container. You should also increase your water hardness setting by 5 grains per gallon (86 mg/L) for every 1 ppm (1 mg/L) of ferrous iron.

Water Characteristics — Softeners require a pH of 7 or above to function properly. An iron test to determine iron levels is also necessary. The 900-NF Acid Neutralizing Filter adjusts pH levels of 6.3 or above.

Water Hardness — Double check hardness of water with test strips provided to verify that your appliance is right for the job.

- Model Pro180 will condition water for up to 70 grains of hardness per gallon (1200 mg/L).
- Model ProPlus380 will condition water for up to 100 grains of hardness per gallon (1710 mg/L). (See Specifications.)

- Water Pressure** — Not less than 20 psi (1.4 bar) or greater than 80 psi (5.5 bar) constant. If water pressure exceeds 80 psi (5.5 bar), a pressure regulator is recommended.
- Water Supply Flow Rate** — A minimum of 3.0 gallons (11.4 L) per minute is recommended. For the purposes of plumbing sizing, only the rated service flow rate and corresponding pressure loss may be used. Prolonged operation of a water conditioner at flow rates exceeding the tested service flow rate may compromise performance.
- Water Temperature** — Not less than 40°F or greater than 100°F (4-38°C).
- Drain** — Drain the appliance to an appropriate drain, such as a floor drain or washer drain that will comply with all local and state plumbing codes. To prevent back-siphoning, provide an adequate air gap or a siphon break. See Installation Steps and Start-Up Procedures.
- Electricity** — The transformer supplied is for a standard 115 volt, 60-cycle AC outlet for locations in North America or 220 volt, 50-cycle AC outlet for locations outside North America.

If you have any questions, call the HelpLine. See General Information at the front of the manual for information about the HelpLine.

PRECAUTIONS

Do

1. Comply with all state and local, building, plumbing, and electrical codes.
2. Test your water quality with the strips provided. Optionally, obtain a report on your water's quality.
3. Install the appliance before the water heater.
4. Install the appliance after the pressure tank on well-water installations.
5. Examine the inlet line to ensure water will flow through it freely and that the inlet pipe size is correct. For well water with iron, the recommended minimum inlet pipe size is 3/4-inch I.D. and for municipal water the recommended minimum inlet pipe size is 1/2-inch I.D.
6. Install a pressure-reducing valve if the inlet pressure exceeds 80 psi (5.5 bar).
7. Install a gravity drain on the cabinet.
8. Secure the drain line on the appliance and at the drain outlet. See Installation Steps and Start-Up Procedures.
9. Allow a minimum of 8 to 10 feet (2.4 to 3.0 m) of 3/4-inch pipe from the outlet of the appliance to the inlet of the water heater.

Do Not

1. Do not install if checklist items are not satisfactory. See Checklist Before Installation.
2. Do not install if the incoming or outlet piping water temperature exceeds 100°F (38°C). See Specifications.
3. Do not allow soldering torch heat to be transferred to valve components or plastic parts when using the optional copper adapters.
4. Do not overtighten the plastic fittings.
5. Do not plumb the appliance against a wall that would prohibit access to plumbing. See Installation Steps and Start-Up Procedures.
6. Do not install the appliance backward. Follow the arrows on the inlet and outlet.
7. Do not plug the transformer into an outlet that is activated by an On/Off switch.
8. Do not connect the drain and the overflow (gravity drain) lines together.
9. Do not use to treat water that is microbiologically unsafe or of unknown quality without adequate disinfection before or after the appliance.
10. Do not allow your appliance or drain line to freeze.
11. Do not allow your appliance to lay on its' side. Keep upright.

Note: A bacteriostasis claim does not mean that these devices will make microbiologically unsafe water safe to consume or use.

The water softener is capable of treating a combination of undesirable constituents (such as iron, dirt, sediment, chlorine, and/or lead) in water. See Specifications for the capabilities of your appliance. Install, set up, and use the appliance within the operating limits outlined in this manual. Failure to comply with these specifications may decrease the effectiveness of the backwash and cause control valve malfunction. The water softener, like any other appliance, requires correct installation and setting for optimum performance. Each water treatment appliance includes water test strips and 15 feet (4.6 m) of drain line.

STEP 1 Site Setup

1. Make sure the placement area is clean.
2. Turn off the electricity and water supply to the water heater. For gas water heaters, turn the gas cock to "Pilot."
3. Examine the inlet plumbing to ensure that the pipe is not plugged with lime, iron, or any other substance. Clean or replace plugged plumbing.

Note: A minimum 3/4-inch pipe is required between the pressure tank and the appliance for the appliance to function properly.

4. Make sure the inlet/outlet and drain connections meet the applicable state and local codes.
5. Check the arrows on the bypass valve to ensure that the water flows in the proper direction. See Bypass Valve.

Caution: Do not plumb the appliance in backward.

6. Place the appliance in the desired location using Figure 1 as a guide. The diagram in Figure 1 applies to basement, slab, crawl space, and outside installations.

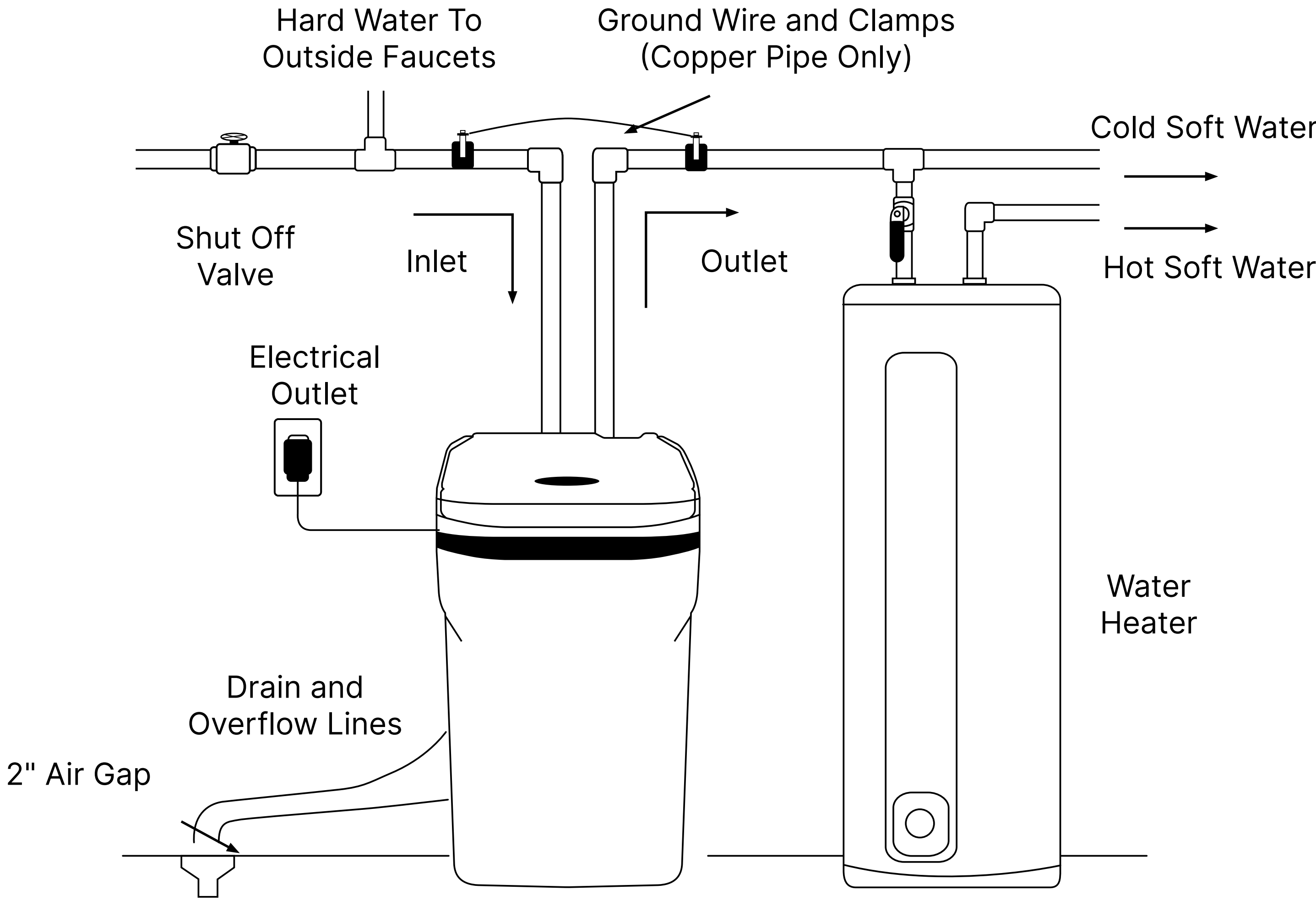

STEP 1 Site Setup, Cont.

7. For most installations, install the appliance after the pressure tank and any water filter appliance or water meter and before the water heater unless otherwise recommended. Contact the HelpLine for further assistance in determining the proper installation sequence.

Water Heaters: If less than 10 feet (3.0 m) of pipe connects the water treatment appliance(s) to the water heater, install a check valve between the water treatment appliance and the water heater as close to the water heater as possible. Ensure that the water heater has an adequately rated temperature and pressure safety relief valve.

8. For outside installations, the appliance should be enclosed so it is protected from the weather.

STEP 2 Turn Off Water Supply

1. Turn off the water supply.
2. Open the hot and cold water taps to depressurize the lines.

STEP 3 Connect Water Lines

1. Lift and remove the cabinet cover.
2. Remove any packaging or installation materials from the brine cabinet.

Note: Teflon tape or plumber's putty is NOT necessary and should NOT be used with Qest fittings.

3. Attach the water lines to the appliance in compliance with all state and local, building, plumbing, and electrical codes. (See Figure 3.) Caution: Do NOT overtighten the connections on the plastic threads.
4. Check the arrows on the valve to ensure that the water flows in the proper direction. Caution: Do NOT plumb your appliance in backward.



Figure 3: Connect Water Lines

STEP 4 **Connect Gravity Overflow Connection**

The overflow line drains away excess water should the tank fill with too much water or the appliance malfunction.

1. Attach the overflow elbow and check that it is in the down position. (See Figure 4.)
2. Connect 1/2-inch I.D. tubing (size cannot be reduced) between the overflow fitting and a suitable floor drain, laundry tub, or other suitable waste receptor. This tubing is not supplied with the appliance. Ensure that the overflow line ends at a drain that is at least 3-inches (8-cm) lower than the bottom of the overflow fitting. Maintain a minimum of 2-inch (5-cm) air gap. The gravity line cannot be run overhead.

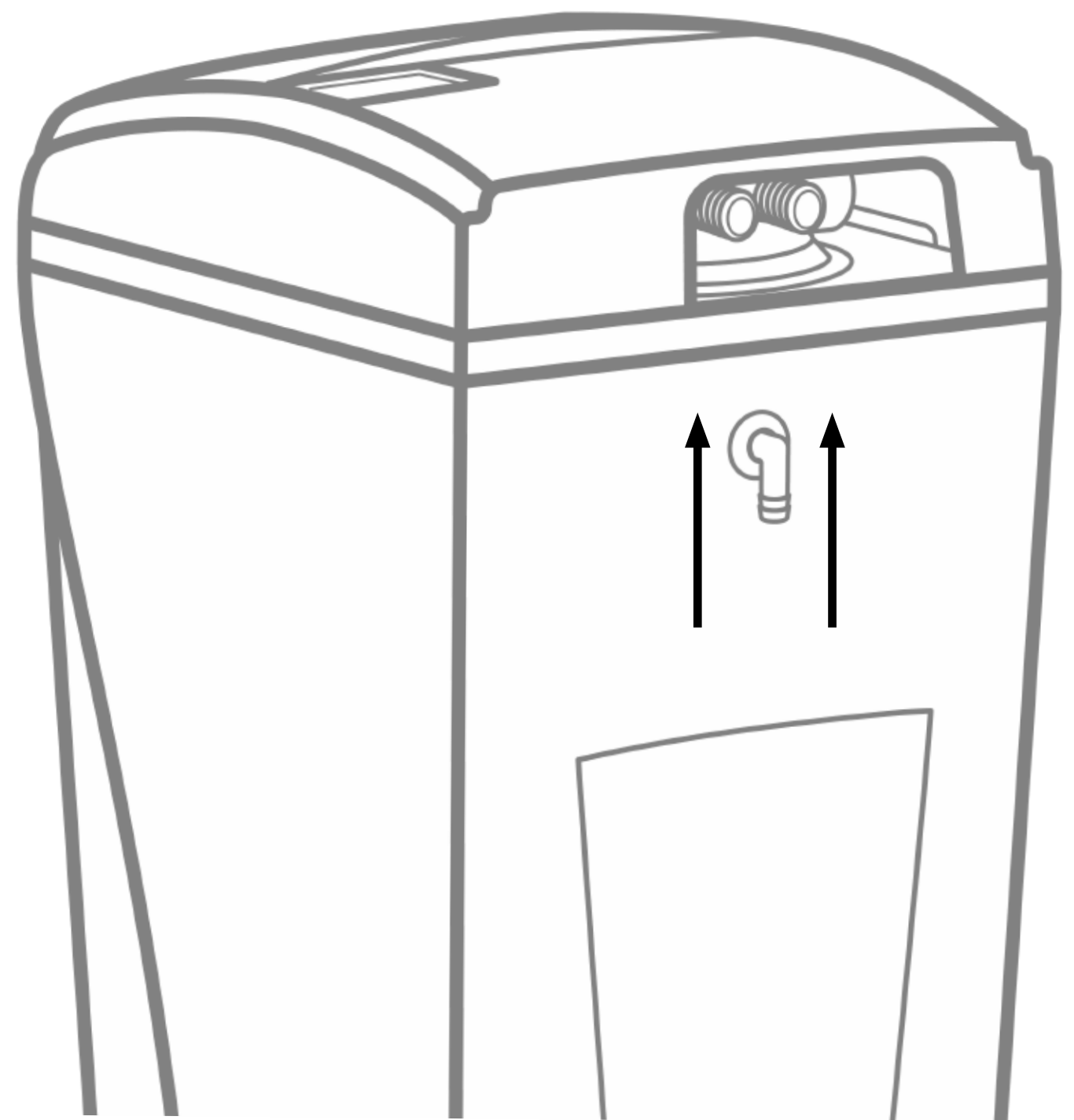

Figure 3: Gravity Overflow Connection

STEP 5 **Connect Drain Line**

The drain line carries away the backwash water as part of the regeneration cycle.

1. Connect the drain line to the drain end cap (See Figure 5) with a minimum 5/8-inch I.D. tubing (supplied). The size cannot be reduced.
 - To prevent leakage, wrap the threads on the drain fitting three times with 1/2-inch wide Teflon tape, or use plumber’s putty.
 - Screw the drain fitting (See Figure 5) into the drain end cap until fewer than three threads are visible.
2. Route the drain line to a floor drain, laundry tub, or other suitable waste receptor. Maintain a minimum 2-inch (5-cm) air gap between the drain line and the flood level rim of the waste receptor to prevent back-siphoning. This drain line should make the shortest run to the suitable drain.
3. The drain line may be elevated up to 8 feet (2.4 m) from the discharge on the appliance as long as the water pressure in your system is 40 psi (2.8 bar) or more.

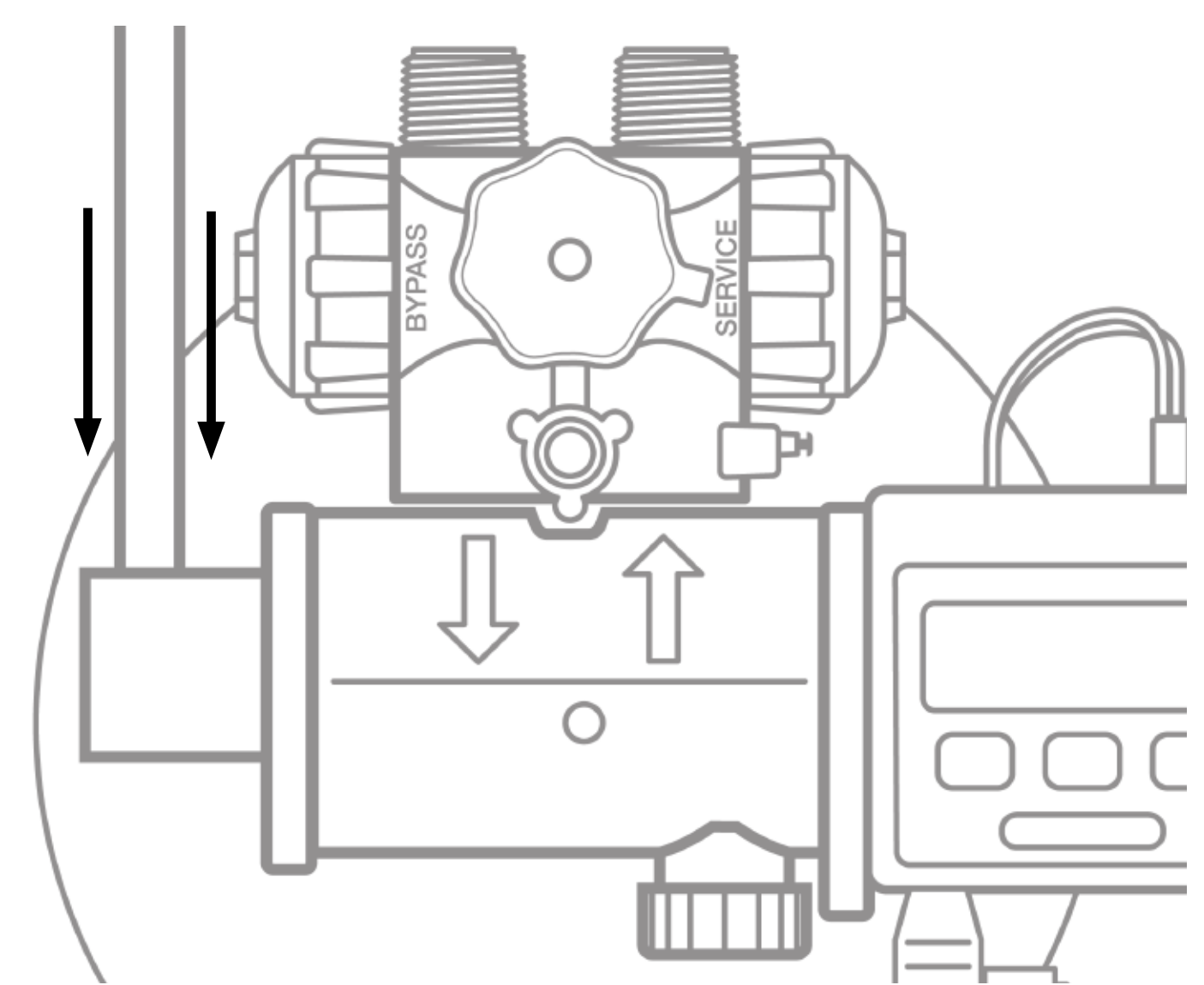

Figure 4: Connect Drain Line

STEP 5 **Connect Drain Line, Cont.**

4. If the drain line is 25 feet (7.6 m) or longer, increase the drain line and adapter to 3/4-inch I.D. The end of the drain line must be equal to or lower in height than the control valve. Caution: The drain line must not be kinked, crimped, or restricted in any way.

STEP 6 **Flush Lines**

1. Place the appliance in the Bypass position. (See Figure 6.)
2. Turn on the main water supply.
3. Open the nearest cold water faucet to flush the plumbing of any excess soldering flux, air, or any other foreign material.
4. Return the appliance to Normal Operation. Note: To prevent untreated water from entering your home, remember to not use water inside your home when the appliance is in Bypass mode. Remember to return the appliance to Normal Operation when you have finished using untreated water.

STEP 7 **Check for Leaks**

1. Close all faucets.
2. Check all lines and connections for leaks. If leaks are found:
3. Turn off the main water supply.
4. Open a cold water faucet to depressurize the lines.
5. Close the faucet to eliminate any siphoning action.
6. Repair all leaks.
7. Turn on the water supply.
8. Place the appliance in the Service position to slowly fill the media tank. (See Figure 6)
9. Open a cold water faucet to purge air out of the media tank.
10. Close the faucet and recheck for leaks.

STEP 8 **Plug in the Transformer**

1. Connect the transformer power cord to the back of the controller. (See Figure 6.)
2. Plug the transformer into an appropriate outlet.
3. Ensure that the outlet selected is not operated by an On/Off switch.

STEP 9 **Set up the Controller**

Program the appliance controller. See Setting the Controller information on [page 14](#).

STEP 10 **Add Water to the Brine Cabinet**

1. Add 2 gallons (8 L) of water to the brine cabinet. After the first regeneration, the appliance will automatically refill the correct amount of water into the brine cabinet.
2. Ensure the appliance is in Service position and your water supply is turned on.
3. Press the R▲ button to advance to the Brine Refill (04) position. Let the tank fill with the proper amount of water. The controller will then step the valve to the Home position. Note: This initial startup is the only time you will add water to the brine cabinet. Do not add water at any other time.

STEP 11 **Fill the Brine Cabinet With Salt**

1. Fill the brine cabinet with salt. Use clean, white pellet or solar salt. Do not mix pellet with solar salt. Note: Always keep the salt level above the water level. For convenience, completely fill the tank when refilling with salt.
2. After you add salt, including adding it after the tank has run out of salt, wait two hours for saturated brine before starting any regeneration. Caution: Use of potassium chloride when iron and/or manganese are present in the raw water supply is not recommended.

STEP 12 **Complete the Installation**

1. Ensure that the appliance is in the Service position. See Figure 6.
2. Ensure the water supply is on.
3. Turn on the electricity and water supply to the water heater. For gas water heaters, return the gas cock to "On."
4. Open a cold water tap and allow the appliance to flush for 20 minutes or until approximately 72 gallons (270 L) have passed through the appliance. This procedure is required to meet NSF requirements. Verify the waterMizer® light is flashing on the controller, which indicates water flow. See Figure 7.
5. Replace the cabinet cover.

Your appliance is equipped with a bypass valve. The bypass valve can isolate the appliance should the appliance malfunction or leak. It can also permit the use of untreated water for watering plants, shrubs, or lawns. The bypass is located on the main control valve. (See Figure 8) To engage the bypass, turn the knob to the Bypass position. The appliance will be bypassed and all water to the home is raw, untreated water. To prevent untreated water from entering the home, water should not be used inside the home when the appliance is in Bypass position. Ensure that the appliance is returned to Service position when the appliance is repaired or the use of untreated water is complete by turning the knob to Service. To blend hardness back into the water using the bypass, turn the knob slightly from the Service position toward the Bypass position.

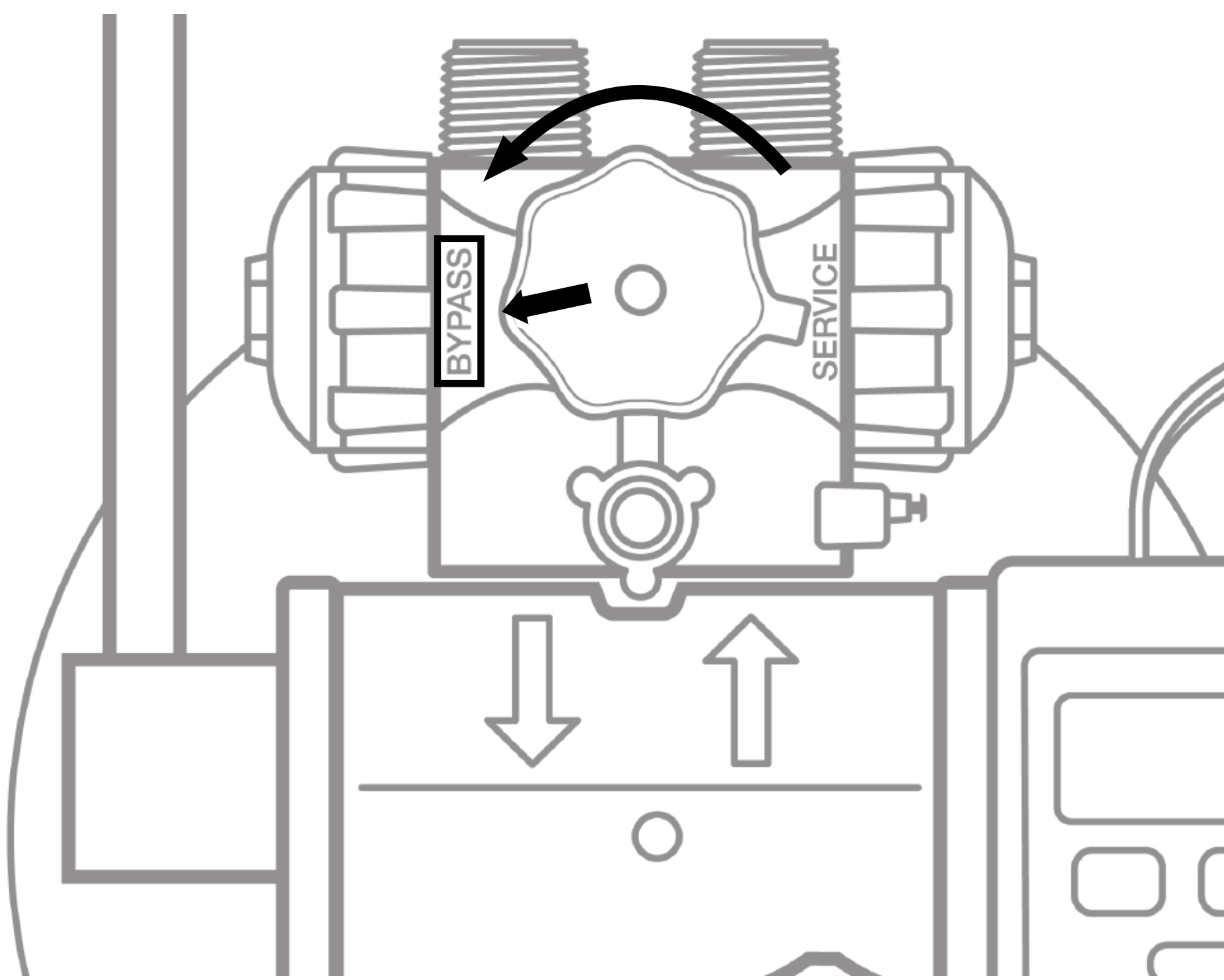

Figure 8: Bypass Valve

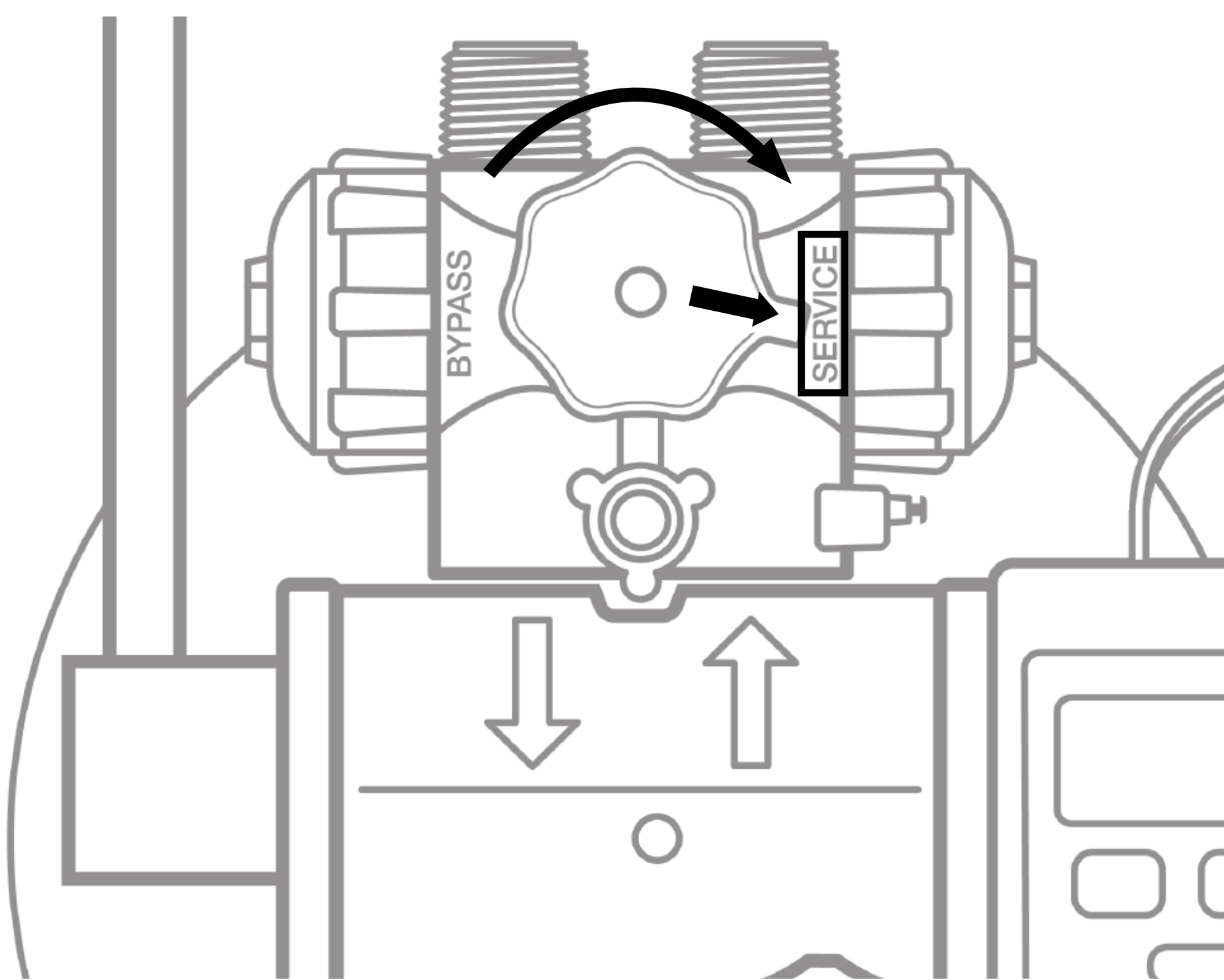

Figure 9: Service Position

This appliance features a four-button controller with an LCD display. The controller can be used to view the appliance’s status, perform regenerations, and change settings. The controller must be set up correctly for the appliance to perform properly.

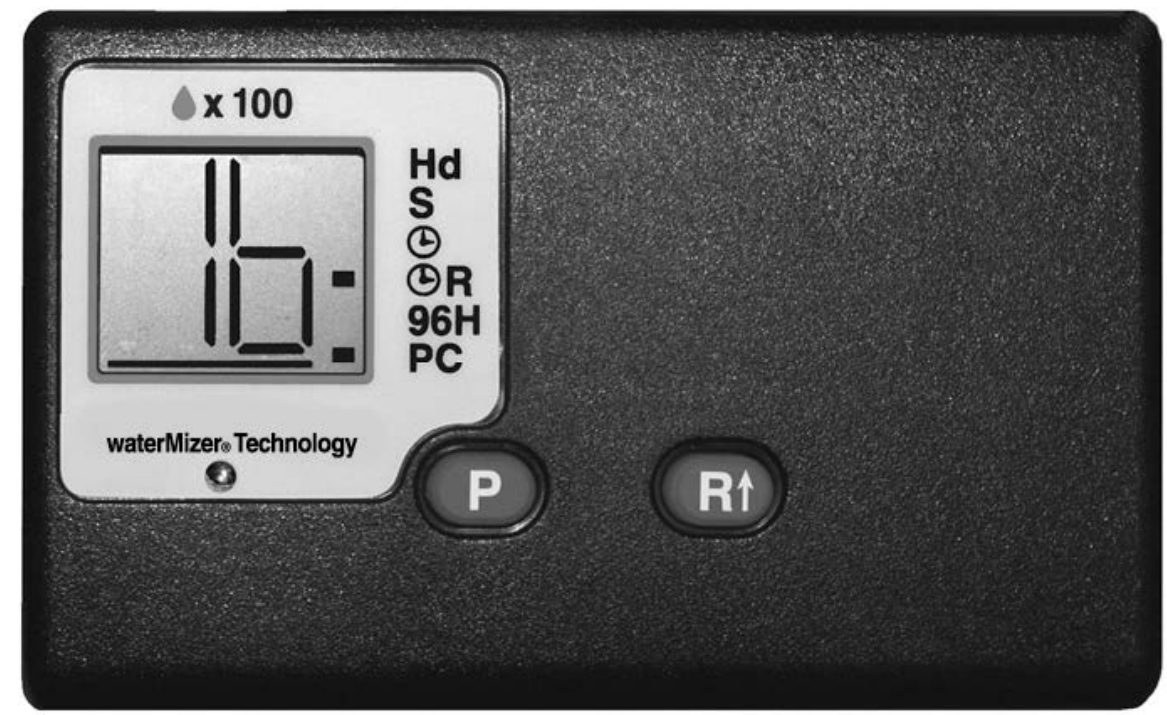





Figure 2: Four-Button Controller

Note: Ensure that the bottom of the controller is firmly locked onto the four tabs on the top of the drive end cap assembly. See Figure 8.

CONTROLLER PART	FUNCTION
LCD Display	Shows the status of the controller
Soft Water Remaining	Shows the gallons (or liters) of soft water remaining until the next automatic regeneration. Typically, each person in the household uses about 75 gallons (284 L) per day. Water remaining is in gallons (or liters) in hundreds. For example 5 = 500 gallons (19 = 1900 liters)
Recharge/ Regeneration Status	Shows regeneration cycle numbers during regeneration. The display will blink the cycle number. The blinking regeneration numbers are: First cycle (01) First Backwash Second and Third cycles (02) Brine/Slow Rinse Fourth cycle (03) Second Backwash Fifth cycle (04) Brine Refill Sixth cycle (HO) Service (Briefly) When regeneration is complete, the display shows the number of gallons (or liters) in hundreds of soft water remaining. (See above) Regeneration is typically completed in about 30 minutes.
waterMizer™	Indicates that water is flowing through the appliance; the waterMizer® light flashes green when water is being used. This is useful for checking for proper plumbing and leaks.

CONTROLLER PART	FUNCTION
Indicator	Shows the controller settings and used to indicate status during programming.
Hd	Blinks when setting the water hardness value.
S	Blinks when choosing a salt setting. Options (S1), (S2), or (SA) will also display.
	Blinks when setting Time of Day (24-hour clock).
 &  R	Both blink when setting Time of Regeneration (24-hour clock).
 R	Blinks when setting Demand/Delayed mode. Blinks when Delayed mode is off (- -); remains lit when Delayed mode is on (). When Delayed mode is off (- -), the appliance is in Demand mode.
96H	Blinks when setting 96-Hour mode. Blinks when 96-Hour mode is off (- -); remains lit when 96-Hour mode is on.
PC	Blinks when setting powerClean™ mode. Blinks when powerClean™ is off (- -); remains lit when powerClean™ is on. Note: powerClean™ is a service/maintenance step for water supplies that have an excessive amount of iron. In powerClean™ mode, each appliance will regenerate every other day with either 5 pounds (2.3 kg) (model Pro180) of salt or 7 pounds (3.2 kg) (model ProPlus380) of salt. Leave the feature on for a minimum of two weeks at a time, every six months, so that the frequent regenerations can eliminate iron buildup in the resin bed. Salt with an iron cleaning agent or iron out cleaner is recommended for continuous use as a preventive measure against iron fouling of the resin bed. Properly using this feature and following these tips will help to ensure a long service life for your appliance.

BUTTON	FUNCTION
P	Used to program and save Customer Settings.
R↑	<p>Used to change Customer Setting values and to start an immediate regeneration (for example, to restore capacity if you run out of salt).</p> <p>To Start an Immediate Regeneration</p> <ol style="list-style-type: none"> 1. Press and hold the R↑ button until the cycle begins. 2. The appliance is in regeneration mode and will display the status of each cycle (for example, 01). 3. After all regeneration cycles are complete, the display will return to Normal Operation. <p>To Quickly Advance Through the Regeneration Cycles (used when starting up or diagnosing the appliance only)</p> <ol style="list-style-type: none"> 1. Press and hold the R↑ button until the cycle begins. 2. The cycle position will display (for example, 01). 3. If the controller does not advance to the next cycle position after 20 seconds, press and hold the R↑ button until the cycle number changes (about 2 seconds). <p>Each cycle can be advanced by pressing the R↑ button. Always wait until the cycle position displays before advancing to the next cycle position.</p>

STEP 1 Determine the Controller Setting Number

For municipal water, call the water department to determine the hardness and pH of your water supply.

For well water, use the hardness test strips provided with your appliance, or have a sample of your untreated water tested by a water testing laboratory.

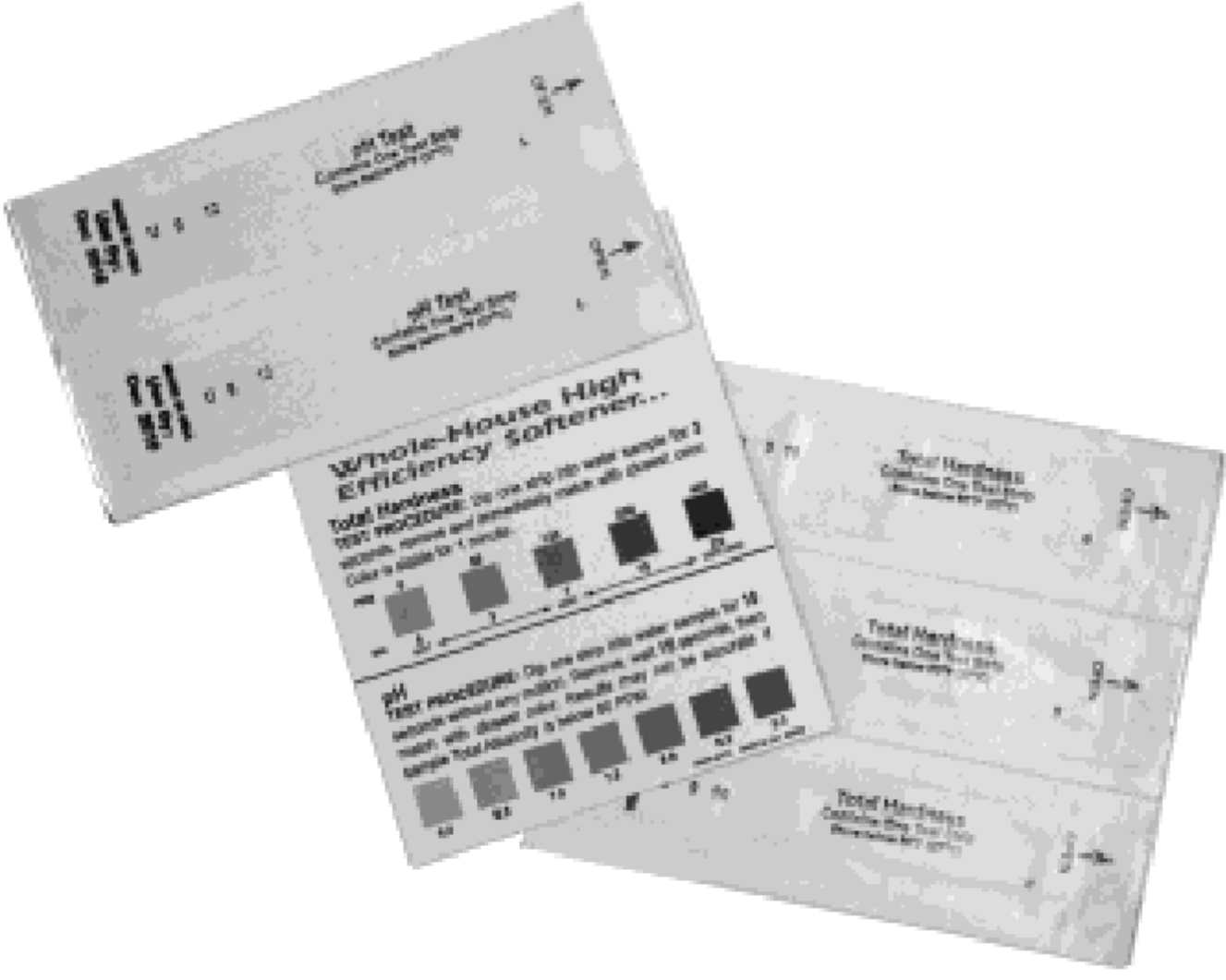

Figure 9: Hardness Test Kits

1. Test Strips—Follow the instructions on the test kits. If the color on your test strip is between two readings, use the higher number. Compare the colors as soon as you remove them from your water. This number gives the hardness in grains per gallon and parts per million (mg/L).
2. Testing Laboratory—To ensure proper settings, have a sample of your untreated water tested for iron and pH.
3. If the pH is below seven, call the HelpLine listed in General Information on page 3 of this manual.
4. Use the following example to determine the controller setting.

IRON TYPE	YOUR WATER	ENGLISH EXAMPLE	METRIC EXAMPLE
Enter hardness grains per gallon (mg/L x 10)		20	34
If your water contains 3 ppm (mg/L) iron, add 15 (26)*	+	+ 15	26
The sum is your controller setting number		32	60

STEP 2 Enter Your Setting Number Into the Controller

1. Press and hold the Set button for about 5 seconds until “25” displays.
2. Press the Change button until the display matches your compensated number. Once you pass “70” (models 700 and 950) or “90” (model 900), the display will reset to “03.”
3. Press Set to save the hardness setting number.
4. To recheck the hardness setting number, hold down the Set button for about 5 seconds.

Note: Refer to Specifications for the maximum water hardness that your appliance can handle.

Most customers will want to use the factory default settings, so no changes are necessary. However, you can reset the controller settings if the factory default settings are not suitable for your needs. If at any time you wish to change the units to metric or restore the controller completely back to factory default settings, see Additional Features.

To Enter Advanced Customer Settings Mode

Press and hold the P and R \blacktriangle buttons at the same time for 3 seconds. The display should show only the controller type 18 (model Pro180) or 38 (model ProPlus380).

STEP 1 Set Salt Setting

1. The S indicator will blink and the display reads (S1), designating the default of Salt Setting #1.
2. Press the R \blacktriangle button momentarily to cycle through the salt settings. There will be two available fixed salt settings and the Automatic Salt Setting.
3. (S1) ensures that for each regeneration, the appliance gets at least 4000 grains per pound (570 grams/kg) of salt. This choice meets or exceeds the requirements some states currently have in regards to salt efficiency.
4. (S2) will provide more capacity between regenerations than S1.
5. (SA) is the automatic salt setting that uses the average daily water usage to determine an appropriate salt dosage, not to exceed the appliance's maximum capacity. Note: This salt setting is recommended for large families and/or water with high levels of hardness. It gives the greatest capacity, if needed.
6. When the desired setting is displayed, press the P button. Note: All models are equipped with patented capacity guard to prevent the over-exhaustion of the resin bed.

STEP 2 Set Time of Day

1. The  indicator will blink and the display reads 00.
2. Press the R \blacktriangle button to cycle through values 00 to 23 representing the Time of Day on a 24-hour clock.

Note: Set time to the nearest hour.

3. When the desired setting is displayed, press the P button. Note: Whenever you experience an electrical outage, check your controller for the correct time. Make any necessary corrections

STEP 3 Set Time of Regeneration

1. Both the ⌚ and the ⌚R indicator will blink and the display reads 02 for the default Regeneration Time of 2:00 a.m.
2. Press the R⬆ button to cycle through values 00 to 23 representing the desired Time of Regeneration on a 24-hour clock. Note: Set time to the nearest hour.
3. When the desired setting is displayed, press the P button.

STEP 4 Set Demand or Delayed Mode

1. The ⌚R indicator will blink and the display reads - -, indicating the default setting of Demand mode.
2. Press the R⬆ button to cycle between - - (Demand mode) or (Delayed mode). If the Delayed mode is active, the ⌚R indicator is displayed during Normal Operation.
3. Delayed mode allows regeneration at a specific time (for example, at 2 a.m. when less water is typically being used).
4. Demand mode triggers a regeneration as soon as softening capacity is exhausted. This is the factory default.
5. When the desired setting is displayed, press the P button.

STEP 5 Set 96-Hour Mode

1. The 96H indicator will blink and the display reads , indicating the default status of on.
2. Press the R⬆ button to cycle between - - and . If the 96-Hour mode is on, the 96H indicator is displayed during Normal Operation. The 96-Hour mode prevents the appliance from going longer than 4 days without a regeneration.

Note: If there is iron in your water, select 96H. On most municipal water supplies or if no water will be used for an extended period of time (for example, going on vacation), turn this option off.

3. When the desired setting is displayed, press the P button and move to the next function.

STEP 6 Set powerClean™ Mode

1. The PC indicator will blink and the display reads - -, indicating the default status of off.
2. Press the R⬆ button to cycle between - - and . This is the only way to turn the powerClean™ mode on or off. Turning on the powerClean™ mode, turns off the 96-Hour mode.
3. When the desired setting is displayed, press the P button and return to Normal Operation.

Advanced programming is now complete.

The controller also has the capability of operating in metric units and of restoring factory defaults. To access these features, follow these steps.

STEP 1 Accessing Additional Features

1. Press and hold the P and R \uparrow buttons at the same time for about 6 seconds. The display should show only the controller type 18 (model Pro180) or 38 (model ProPlus380) in solid numbers, change to blinking numbers, and then go back to solid numbers.
2. Once the numbers are solid again, release the buttons and enter the code P, P, R \uparrow , P. This code will enter you into the Unit Selection screen. Note: Entering any combination other than the above code will put you into Advanced Settings.

STEP 2 Set Units

1. The indicator bar below the digits will blink and the display reads - -, designating the default of English units (gallons).
2. Press the R \uparrow button to cycle between - - (off) and (on). Choosing will set the units to metric (liters). When metric units are active, the indicator bar below the digits is displayed during Normal Operation.
3. When the desired setting is displayed, press the P button.

STEP 3 Restore Factory Defaults

1. All of the side indicators will blink and the display reads - -.
2. To restore factory defaults, press the R \uparrow button to cycle the display to . If you want to retain your current settings, leave the display showing - -.
Note: Restoring the factory defaults will erase any programming you have done, including changing the controller units and setting the clock
3. When the desired setting is displayed, press the P button and return to Normal Operation.

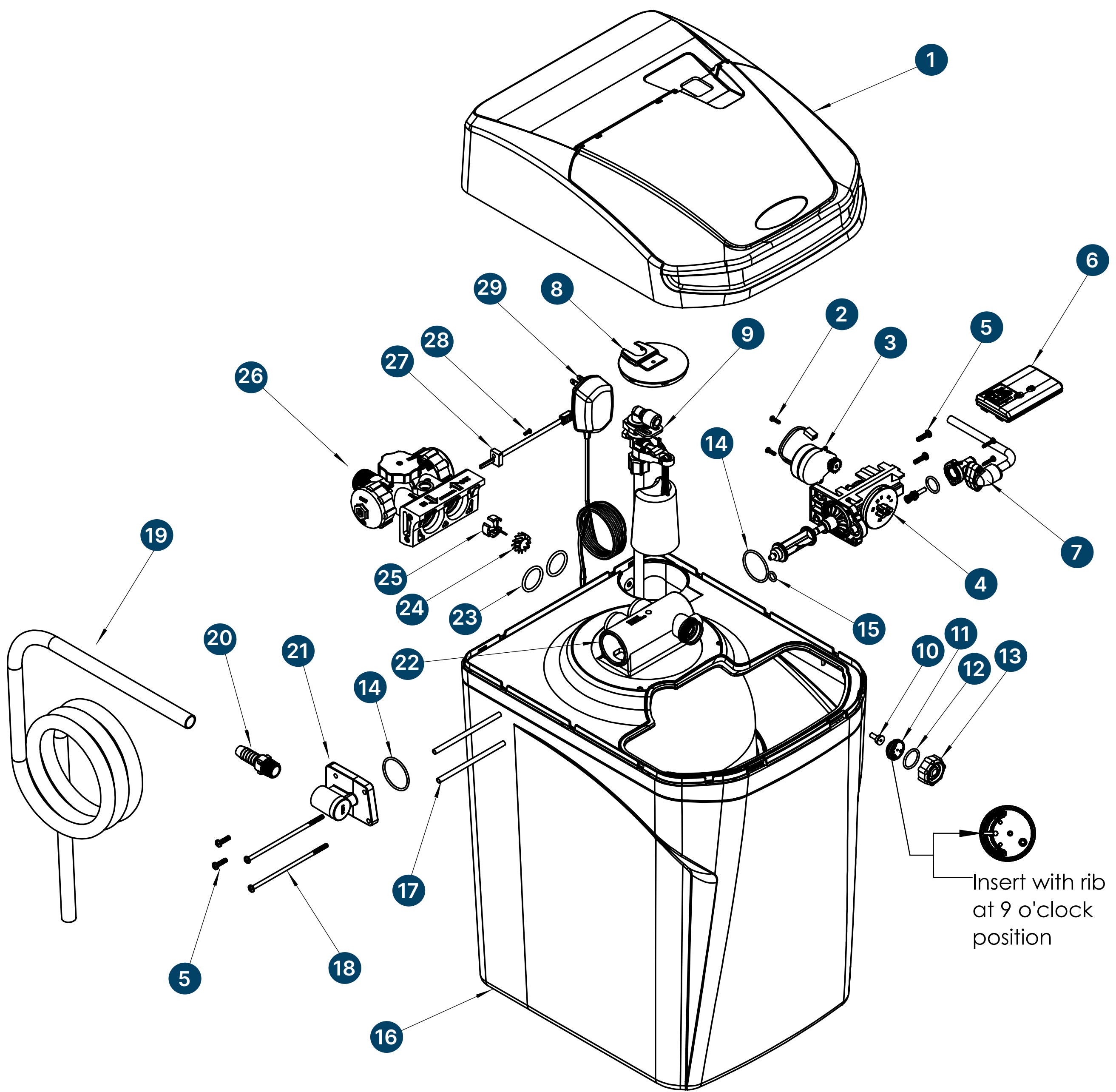

DESCRIPTION	QTY.
1 Valve Cover Assembly	1
2 Screw	2
3 12 Volt Motor	1
4 Drive End Cap Assembly	1
5 Screw	4
6 180/380 Computer Control Assembly	1
7 Brine Valve Assembly	1
8 Brine Well Cover	1
9 180/380 Safety Shutoff	1
10 Injector Throat	1
11 Injector Nozzle with Over-Mold Gasket	1
12 O-Ring	1
13 Injector Cap	1
14 O-Ring	2
15 O Ring	1

DESCRIPTION	QTY.
16 180/380 Cabinet	1
17 Sleeve	2
18 Screw	2
19 1/2" ID Drain Line	1
20 Drain Fitting, 1/2-inch MNPT x Barb	1
21 180/380 Drain End Cap	1
22 180/380 Media Tank with Resin	1
23 O-Ring	2
24 Turbine Assembly	1
25 Plastic Turbine Axle	1
26 Bypass Valve Assembly	1
27 Turbine Sensor/Cap Assembly	1
28 Sensor Cap Screw, Self-Tapping	1
29 12V Transformer/Power Cord	1

	PRO180	PROPLUS380
Maximum Compensated Hardness—gpg (mg/L)	70 (1200)	100 (1710)
Maximum Capacity—grains (grams)	18000 (1166)	38000 (2462)
Maximum ferrous iron reduction¹	10 ppm ¹	10 ppm ¹
Minimum pH (standard units)	7	7
Media type and amounts	Self-Cleaning Filter Media— 1.5 lb (0.7 kg) KDF Media—2.0 lb (0.9 kg) Fine Mesh Resin—0.7 cu. ft. (20 L)	Self-Cleaning Filter Media— 1.5 lb (0.7 kg) KDF Media—2.0 lb (0.9 kg) Fine Mesh Resin—1.25 cu. ft. (35 L)
Salt^{2,3}—Pounds (kg) Capacity— Grains (grams) Water— Gallons (L) Time— Minutes	2 8140 grains 16.4 gal (62 L) 21	6 27100 grains 25.4 gal (96 L) 39
Salt²—Pounds (kg) Capacity— Grains (grams) Water— Gallons (L) Time— Minutes	6 17150 grains 20.7 gal (62 L) 29	10 34650 grains 29.7 gal (112 L) 47.5
Minimum / Maximum water and ambient temperature—oF (oC)	40/100 (4 - 38)	40/100 (4 - 38)
Mineral tank size—in. (cm)	10.5 I.D. x 19 (26.7 I.D. x 48.3)	11.5 I.D. x 28 (29.2 I.D. x 71.1)
Peak flow rate—gpm (L/min)	8 (30)	8.2 (31)
Pressure drop at service flow rate of 8 gpm (30.3 L/min)—psi (bar)	15 (1.0)	14.6 (1.0)
Maximum flow rate to drain during regeneration—backwash gpm (L/min)	3.0 (11.4)	3.0 (11.4)
Minimum / Maximum Water Pressure—psi (bar)	20/80 (1.4/5.5)	20/80 (1.4/5.5)
Minimum water flow required—gpm (L/min)	3.0 (11.4)	3.0 (11.4)
Controller type	2 Button	2 Button
Frequency of regeneration	Demand	Demand

	PRO180	PROPLUS380
Salt storage—lb (kg)	120 (55)	170 (78)
Height—in. (cm)	25.5 (64.8)	33.4 (84.8)
Footprint—in. (cm)	15 × 19 (38 × 48)	16.5 × 20 (42 × 51)
Electrical rating	12 VAC, 50/60 Hz, 0.015kW-hr	12 VAC, 50/60 Hz, 0.015kW-hr
Plumbing connections	1-inch male (NPT)	1-inch male (NPT)
Shipping weight— approximate—lb (kg)	85 (39)	135 (61)

¹ The state of Wisconsin limits iron reduction claims to 5 ppm.

² Use clean, white pellet or solar salt.

³ This is the default salt dosage. This setting meets the requirement some states have regarding salt efficiency.

Efficiency Statements

This product is efficiency rated according to NSF/ANSI 44. The stated efficiencies are valid only at the specified salt dosage and 8 gpm (30 L/min):

MODEL	RATED EFFICIENCY	SALT DOSAGE	CAPACITY AT THAT DOSAGE
Pro180	5066 grains/lb (722 grams/kg)	1 lb (0.45 kg)	5066 grains (328 grams)
ProPlus380	5510 grains/lb (785 grams/kg)	1 lb (0.45 kg)	5510 grains (357 grams)

PROBLEM	POSSIBLE CAUSE	SOLUTION
No Soft Water After Regenerations	No salt in brine cabinet.	Add salt.
	Drain line is pinched, frozen, or restricted.	Straighten, thaw, or unclog the drain line.
	Clogged injector assembly.	Remove injector cap and clean nozzle and throat with a wooden toothpick. Replace throat if removed.
	Salt bridge has formed due to high humidity or the wrong kind of salt.	Test with a blunt object like a broom handle. Push the handle into the salt to dislodge the salt bridge, or use hot water around the inside perimeter to loosen salt.
No Soft Water	The bypass valve is in the Bypass position.	Place the bypass valve in the service position.
	Appliance is plumbed backward.	Check that appliance is plumbed correctly.
	Extended power outage.	Reset the time of day.
	Not metering water.	waterMizer indicator should turn with water usage. If no flow, see below.
	Sensor not receiving signal from magnet on turbine.	Remove sensor from Bypass housing. Test with magnet on either flat side of sensor. If flow is indicated, check turbine. If no flow, replace sensor.
Flow indicated when water is not being used	The household plumbing system has a leak.	Repair the leak.
No read-out in display	Electric cord is unplugged.	Plus in the transformer.
	No electric power at outlet.	Check power source. Make sure outlet is not controlled by a switch.
	Defective transformer.	Test with volt meter for 12 VAC at control. If less than a 10 VAC or greater than 14 VAC, replace the transformer.
	Defective circuit board.	With 12 VAC present at controller, replace the controller.

PROBLEM	POSSIBLE CAUSE	SOLUTION
Appliance stays in regeneration	Controller not attached properly.	Make sure the controller is pushed all the way onto the drive end cap.
	Defective magnet disk.	Replace magnet disk.
	Foreign object in valve body.	Remove foreign object(s) from the valve body.
Excess water in brine cabinet	Restricted, frozen, or pinched drain line.	Remove restriction, thaw, or straighten drain line.
	Plugged injector assembly.	Clean or replace injector. Replace throat if removed.
Salty Water	Plugged injector.	Replace injector screen, nozzle, and throat.
	Low water pressure.	Maintain minimum pressure of 20 psi (1.4 bar).
Controller error messages	"E1" Home not found.	Cycle power by unplugging the transformer and plugging it back in. It will look for Home again. Make sure the controller is pushed all the way onto the drive end cap.
	"E2" Motor error.	Plug motor in and cycle power. If it is already plugged in, then motor wiring or the motor plug is defective.
	"E3" Home offset.	Disk did not start in proper home location. Controller will automatically try to reset itself by finding Home and continuing the regeneration. Make sure the controller is pushed all the way onto the drive end cap.
	"E4" Home latched	Gear teeth are not engaged, gear is stripped, or something is jammed in the valve. Cycle the power to reset.
	"E5" Memory error.	Replace controller.

To Whom Warranty Is Extended

This warranty is issued to the original owner at the original location site and is not transferable to other sites or to subsequent owners of the system.

To register your product under warranty, please visit www.waterboss.com/product-registration. Registration is not required but if done within 30 days of purchase, will qualify as proof of the original ownership.

Coverage

This limited warranty covers the WaterBoss® system delivered to the original owner at the original location when the system is purchased for personal, family, or household use. It is intended to cover defects occurring in workmanship or materials or both.

Warrantor's Performance and Length of Limited Warranty

WaterBoss® warrants that upon receipt from the original owner of any mechanical or electronic part which is found to be defective in materials or workmanship, WaterBoss® will repair or replace the defective item for 5 years from date of original installation. Media is not warranted.

WaterBoss® further warrants that upon receipt from the original owner of any WaterBoss® media tank/ main control valve, brine cabinet, found to be defective in material or workmanship, WaterBoss® will repair or replace the defective item for 10 years from date of original installation.

All defective parts must be returned, along with the equipment serial number and date of original installation, to WaterBoss® PREPAID, and replacement parts will be returned by WaterBoss® to the original owner FREIGHT COLLECT. The limited warranty on any replacement part of whole unit is limited to the unexpired portion of the warranty.

Further Exclusions and Limitations on Warranty

THERE ARE NO WARRANTIES OTHER THAN THOSE DESCRIBED IN THIS WARRANTY INSTRUMENT.

This warranty does not cover any service call or labor costs incurred with respect to the removal and replacement of any defective part or parts.

WaterBoss® will not be liable for, nor will it pay service call or labor charges incurred or expended with respect to this warranty.

In the event the water supply being processed through this product contains sand, bacterial iron, algae, sulphur, tannins, organic matter, or other unusual substances, then, unless the system is represented as being capable of handling these substances in the system specifications, other special treatment of the water supply must be used to remove these substances before they enter this product. Otherwise, WaterBoss® shall have no obligations under this warranty.

This warranty does not cover damage to a part or parts of the system from causes such as fire, accidents, freezing, or unreasonable use, abuse, or neglect by the owner.

This warranty does not cover damage to a part or parts of the system resulting from improper installation. All plumbing and electrical connections

should be made in accordance with all local codes and the installation instructions provided with the system. The warranty does not cover damage resulting from use with inadequate or defective plumbing; inadequate or defective water supply or pressure; inadequate or defective house wiring; improper voltage, electrical service, or electrical connections; or violation of applicable building, plumbing, or electrical codes laws, ordinances, or regulations.

THIS WARRANTY DOES NOT COVER INCIDENTAL, CONSEQUENTIAL, PUNITIVE OR SECONDARY DAMAGES. ANY IMPLIED WARRANTIES ON THE PRODUCT DESCRIBED IN THIS WARRANTY WILL NOT BE EFFECTIVE AFTER THE EXPIRATION OF THIS WARRANTY.

No dealer, agent, representative or other person is authorized to extend or expand this limited warranty.

Some states do not allow limitations on how long an implied warranty lasts or the exclusion or limitation of incidental or consequential damages, so the above limitations and exclusion may not apply to you. This warranty gives you specific legal rights and you may also have other rights which vary from state to state.

Claims Procedures

Any defects covered by this warranty should be promptly reported to:

WaterBoss®

4343 S. Hamilton Rd.

Groveport, OH 43125

When writing about the defects, please provide the original owner's name, telephone number, and original address, serial number and model number of the product, and date of purchase. (This information should be listed in General Information at the front of this manual.) A. O. Smith Water Treatment (North America), Inc. reserves the right to replace defective parts with exact duplicates or their equivalent.



WaterBoss®
4343 S Hamilton Rd | Groveport, OH 43125
Phone: 1-800-437-8993